

Samsung FJM Series, 2 Port Condensing Unit

Job Name _____
 Purchaser _____
 Submitted to _____
 Unit Designation _____

Location _____
 Engineer _____
 Reference _____ Approval _____ Construction _____
 Schedule # _____



Model	US Code	JXH20J2T
	Model Number	AJ020TXJ2CH/AA

Performance*	Capacity (standard / max.)	Cooling (Btu/h)	18,000 / 18,000
		Heating (Btu/h)	22,000 / 26,400
	Minimum Cooling Capacity (Btu/h)		5,500
	Minimum Heating Capacity (Btu/h)		3,500
	SEER (Ducted / Mixed / Non-ducted)		18.0 / 18.75 / 19.5
	EER (Ducted / Mixed / Non-ducted)		11.1 / 11.9 / 12.7
HSPF (Ducted / Mixed / Non-ducted)		9.5 / 9.75 / 10.0	

Power	Voltage	øV/Hz	1 / 208-230 / 60
	Rated Current (amps) ¹	Cooling (low / std. / max.)	2.2 / 6.7 / 6.7
		Heating (low / std. / max.)	1.9 / 8.4 / 10.9
	Max. Breaker	Amps	20
Minimum Circuit Ampacity (A)		16.5	

Dimensions	W X H X D	Inches	34 5/8 X 31 7/16 X 12 3/16
	Weight	lbs.	116.8

Noise Level	Cooling (Max.)	dB (A)	48
	Heating (Max.)	dB (A)	51

Operating Temperatures	Cooling	14 ~ 114.8°F (-5 ~ 46.0°C)
	Heating	5 ~ 75°F (-15 ~ 24.0°C)

Pipe Connections	High Side	1/4" X 2	
	Low Side (suction)	3/8" X 1 + 1/2" X 1	
	Maximum Individual Line Set Length	82 ft	
	Maximum Line Set Length (total)	164 ft	
	Maximum Vertical Separation	Outdoor to Indoor	49 ft
		Highest to Lowest Indoor	25 ft
Included Pipe Adapter	1 - 1/2" X 3/8"		

Condenser Fan	Motor	BLDC With Propeller Fan (1)	
	Output	Watts / FLA	125 / 1.28
		CFM	1,667

Compressor	Type	Twin BLDC Rotary Inverter
	RLA	Amps

Heat Exchanger	Type	Aluminum Fin - Copper Tube
	Rows	2

Refrigerant	Type	R410A
	Control Method	Electronic Expansion Valve
	Factory Charge	77.6 oz
	Charged for	98 ft
Additional Refrigerant		0.11 oz/ft over 98 ft

Accessories	Wall Bracket	CKN-250
-------------	--------------	---------

Certifications	Safety	ETL (UL 1995)	
	AHRI Certification Number	Non-Ducted	205291853
		Ducted	205236961
		Mixed	205343310

Warranty	10 Years compressor, 10 year parts, 1 year limited labor (registration required)
----------	--

* Certified in accordance with the AHRI Unitary Small Air-Source Heat Pumps (USHP) Certification Program which is based on the latest edition of AHRI Standard 210/240. Refer to www.AHRIdirectory.org for current reference numbers.

¹ Rated current is based on highest combination ratio of non-ducted indoor units.

Samsung HVAC maintains a policy of ongoing development, specifications are subject to change without notice.

- Auto or manual addressing of indoor units
- The outdoor unit shall supply power individually to the indoor units via 14 AWG X 3 power wire
- Soft-start to reduce current demand during compressor start
- Auto-restart after power loss
- System can be set up as heating/cooling, cooling only, or heating only via outdoor unit option setting.
- Available maximum current setting option to reduce maximum operating current.
- System energy consumption can be viewed using Samsung SmartThings mobile app (not revenue grade, for reference only).

Construction

The outdoor unit shall be galvanized steel with a baked on powder coated finish for durability

Heat Exchanger

The heat exchanger shall be mechanically bonded fin to copper tube

Controls

Control signal shall be a DDC type signal

Interconnect control wire between outdoor and indoor units shall be 16AWG X 2

The system shall integrate with the Samsung Controls Solution without the use of an interface module.

Refrigerant System

The refrigerant shall be R410A

The compressor shall be hermetically sealed, inverter controlled, Twin BLDC Rotary

Refrigerant flow shall be controlled by 2 separate electronic expansion valves at outdoor unit

Compatibility

Will only operate with Samsung evaporator model numbers:
 AR**TSFABWKNCV (RNS**ABT): 7,000 - 15,000 Btu/h models
 AR**TSFYBWKNCV (RNS**YBT): 7,000 - 15,000 Btu/h models
 AJ**TNNDCH/AA (JNH**NDT): 9,000 - 12,000 Btu/h models
 AJ**TNLDCH/AA (JNH**LDT): 9,000 - 12,000 Btu/h models
 AJ**TNJDCH/AA (JNH**JDT): 9,000 - 15,000 Btu/h models

Proper sizing and installation of equipment is critical to achieve optimal performance. Split system air conditioners and (excluding ductless systems) must be matched with appropriate coil components to meet ENERGY STAR® criteria. Ask your contractor for details or visit www.energystar.gov.



Samsung FJM, 2 Port Condensing Unit

Dimensional drawing

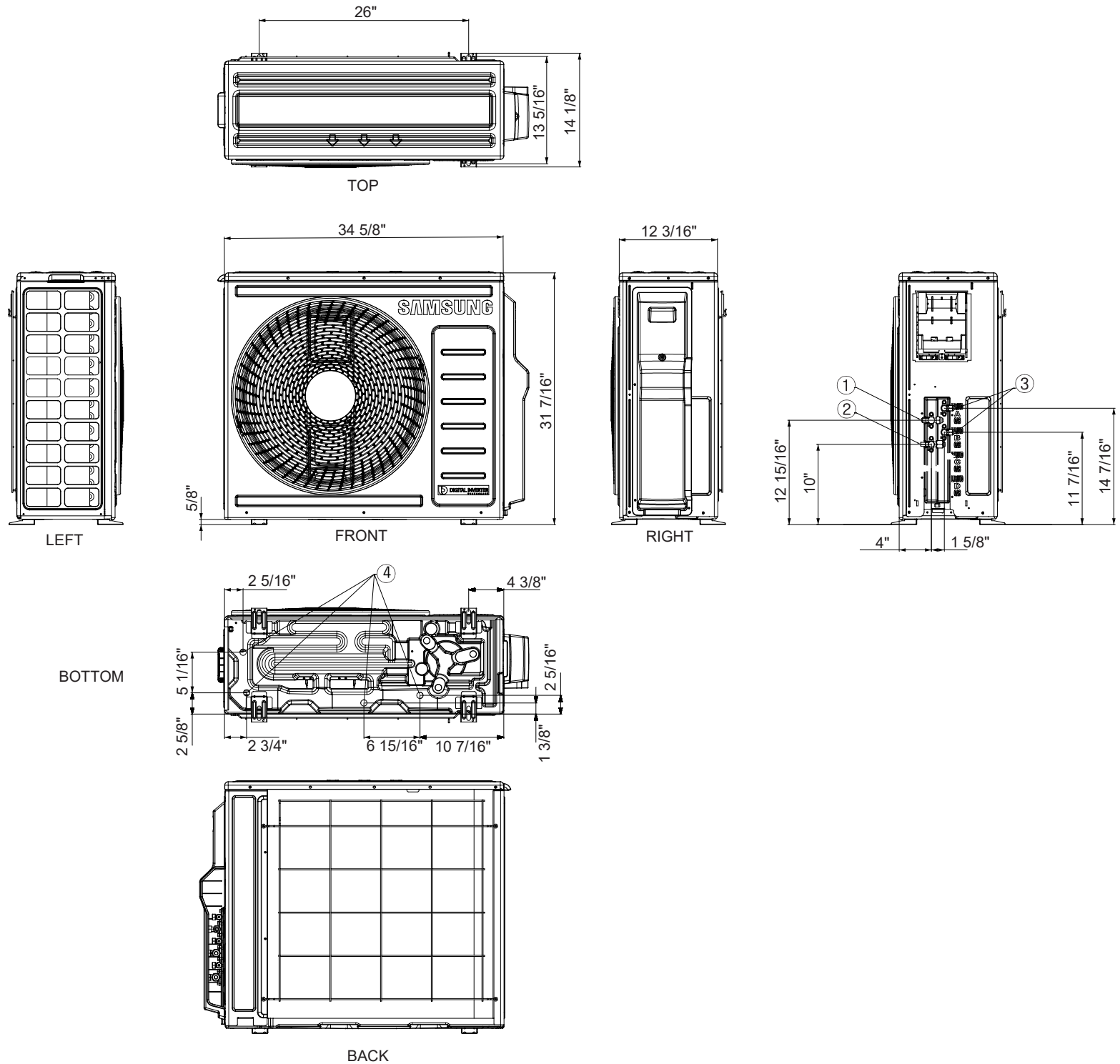

No.	Name	Description
1	Refrigerant suction pipes	ø3/8" x 1 each
2		ø1/2" x 1 each
3	Refrigerant liquid pipes	ø1/4" x 2 each
4	Drain holes	Connection with provided drain fitting

Indoor Unit Connection Options

		Indoor Unit Capacity (Btu/h)	
		A	B
2 Indoor Units	7,000	7,000	
	7,000	9,000	
	7,000	12,000	
	7,000	15,000	
	9,000	9,000	
	9,000	12,000	
	9,000	15,000	
	12,000	12,000	
	12,000	15,000	

Must have a minimum of 2 indoor units connected. Will only operate with Samsung evaporator model numbers listed below:

- AR**TSFABWKNCV (RNS**ABT): 7,000 - 15,000 Btu/h models
- AR**TSFYBWKNCV (RNS**YBT): 7,000 - 15,000 Btu/h models
- AJ**TNNNDCH/AA (JNH**NDT): 9,000 - 12,000 Btu/h models
- AJ**TNLNDCH/AA (JNH**LDT): 9,000 - 12,000 Btu/h models
- AJ**TNJDCH/AA (JNH**JDT): 9,000 - 15,000 Btu/h models

Basic Wire Connection Diagram

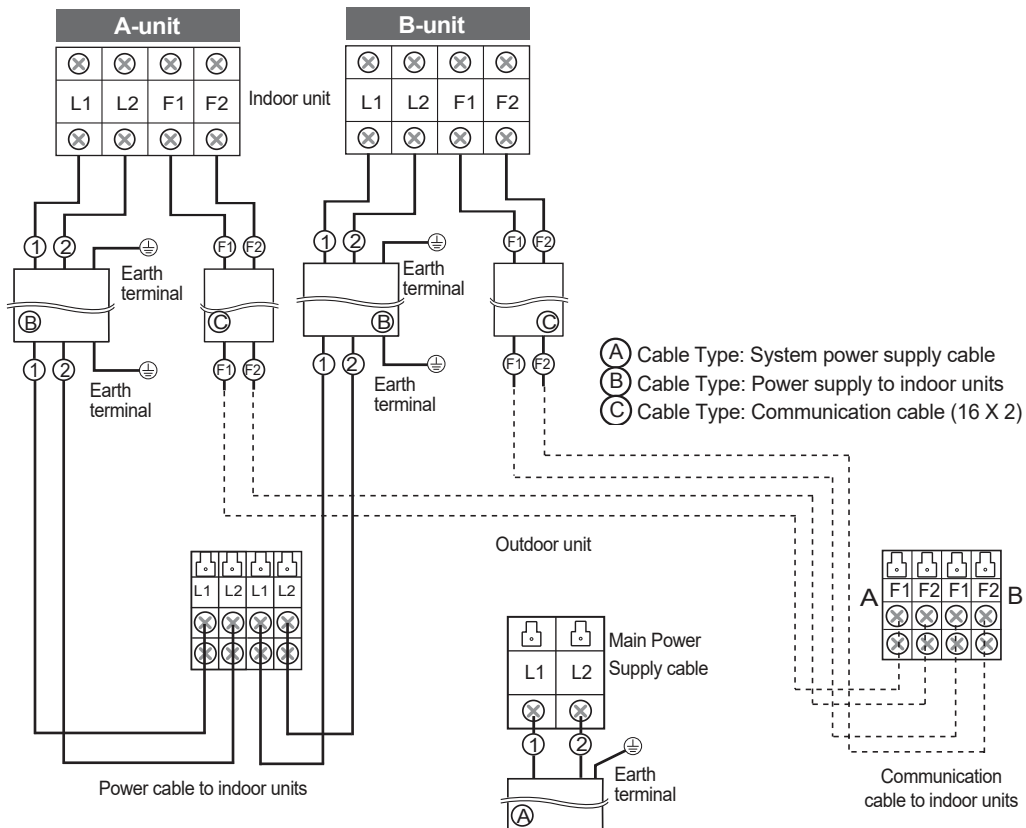

This simple wiring diagram is for reference only. Please refer to installation manuals for full details and requirements.